

SGF98HVLP AND SGF98 GRAVITY FEED SPRAY GUNS

SGF98

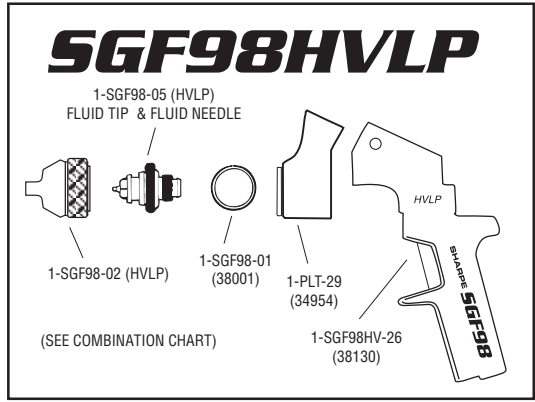
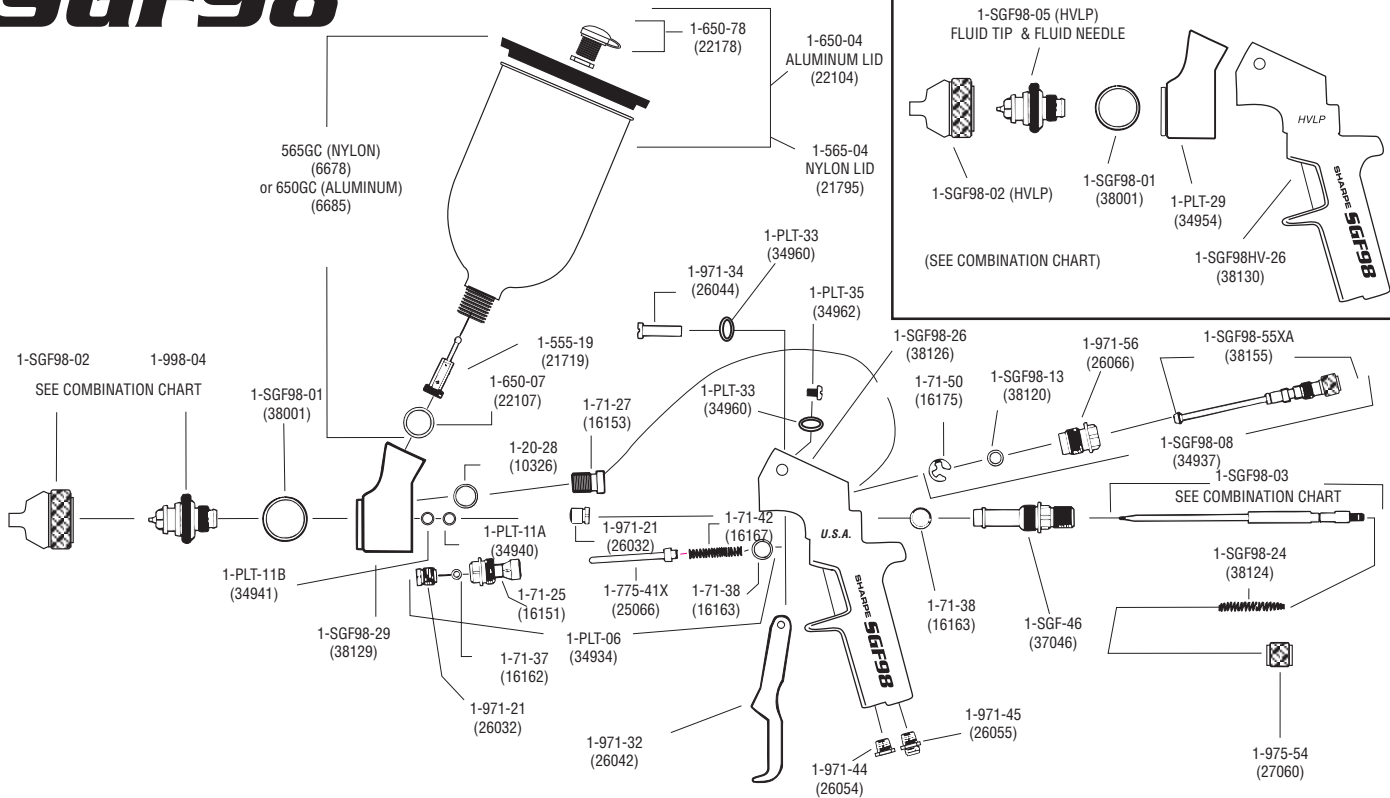

SERVICE KIT
1-SGF98RK
(COMP. NO. 38160)

COMBINATION CHART FOR MODEL SGF98HVLP SPRAY GUNS					
SPRAY GUN W/ NYLON CUP	SPRAY GUN W/ ALUMINUM CUP	AIR CAP	FLUID TIP & NEEDLE MATCHED SET	AIR CONSUMPTION INLET PRESSURE AIR CAP PRESSURE	REMARKS
(1.0mm) SGF98-HVLP-1.0 Comp. #5910	(1.0mm) SGF98-HVLP-1.0 Comp. #5910A	1-SGF98-02#1.0 Comp. #38010	1-SGF98-05-1.1 Comp. #38111	12.9 CFM @ 43 PSI 8 PSI	Small Areas Very Fine Atomization
(1.3mm) SGF98-HVLP-1.3 Comp. #5913	(1.3mm) SGF98-HVLP-1.3 Comp. #5913A	1-SGF98-02#1.3 Comp. #38013	1-SGF98-05-1.3 Comp. #38113	12.9 CFM @ 43 PSI 8 PSI	High Solids Colors and Clears
(1.5mm) SGF98-HVLP-1.5 Comp. #5915	(1.5mm) SGF98-HVLP-1.5 Comp. #5915A	1-SGF98-02#1.5 Comp. #38015	1-SGF98-05-1.5 Comp. #38115	12.9 CFM @ 43 PSI 8 PSI	High Solids Colors and Clears
(1.7mm) SGF98-HVLP-1.7 Comp. #5917	(1.7mm) SGF98-HVLP-1.7 Comp. #5917A	1-SGF98-02#1.7 Comp. #38017	1-SGF98-05-1.7 Comp. #38117	12.9 CFM @ 43 PSI 8 PSI	High Viscosity Materials Including Enamels

COMBINATION CHART FOR SGF98 SPRAY GUNS					
MODELS AVAILABLE	AIR CAP	FLUID TIP	FLUID NEEDLE	AIR CONSUMPTION	REMARKS
(1.4mm) SGF98-GP-55 Comp. #5885	1-SGF98-02#GP Comp. #38002	(.055) 1-998-04-55NI Comp. #27255	1-SGF98-03-45N Comp. #27004	11.0 CFM @ 50 PSI	All Automotive Colors and Clears
(1.2mm) SGF98-A-45 Comp. #5890	1-SGF98-02#A Comp. #38004	(.045) 1-998-04-45NI Comp. #27245	1-SGF98-03-45N Comp. #27004	13.8 CFM @ 50 PSI	High Solids Colors and Clears (Small Areas)
(1.2mm) SGF98-C-45 Comp. #5895	1-SGF98-02#C Comp. #38006	(.045) 1-998-04-45NI Comp. #27245	1-SGF98-03-45N Comp. #27004	13.8 CFM @ 50 PSI	High Solids Clears

